

WORLD MARKET®

Assembly Instructions

PALMERA RECTANGLE TABLE

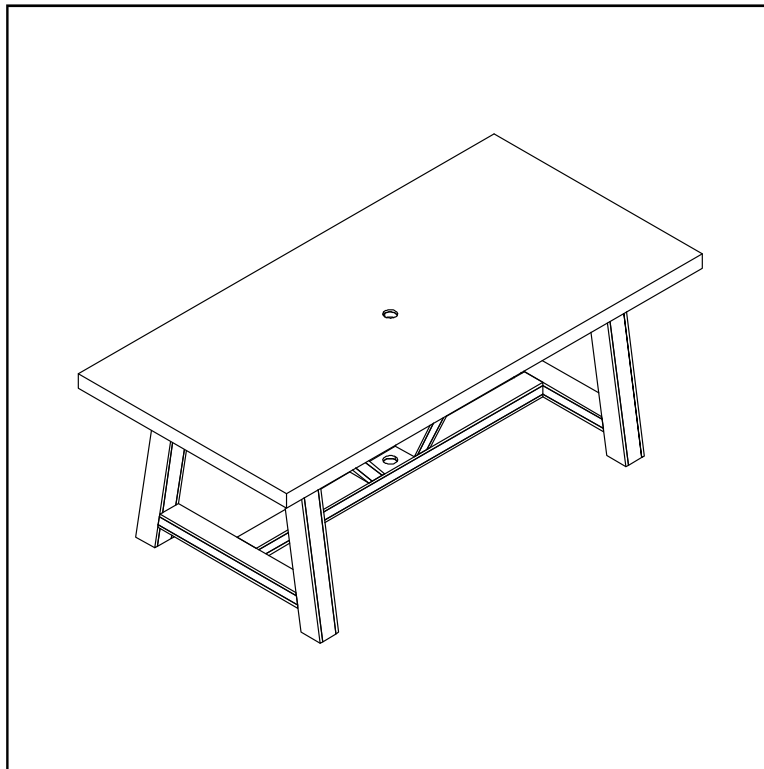

SKU-585020







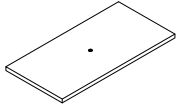
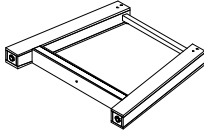
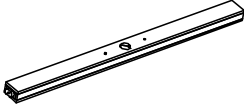

THANK YOU FOR YOUR PURCHASE. IF YOU HAVE ANY QUESTIONS
PERTAINING TO THE ASSEMBLY OF THIS FURNITURE PIECE, PLEASE CONTACT
NEAREST WORLD MARKET STORE.
IF YOU ARE NOT NEAR A STORE, PLEASE CALL OUR CUSTOMER SERVICE CALL
CENTER TOLL FREE AT 877- 967-5362 FOR ASSISTANCE.

NOT FOR COMMERCIAL USE.

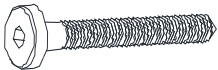
Component List

LABEL	PICTURE	DESCRIPTION	QTY
A		Table Top	1
B		Leg	2
C		Lower Wood Crossbar	1
D		Upper Wood Support Bar	2
E		Umbrella Hole Cap	1

Hardware

LABEL	PICTURE	DESCRIPTION	QTY
H-1		Short Allen Bolt M6x65mm	3
H-2		Medium Allen Bolt M8x80mm	4
H-3		Barrel Nut M8	2
H-4		Long Allen Bolt M8x110mm	8
H-5		Spring Washer M8 Ø 11.5 mm x 1.2 mm	8
H-6		Flat Washer M8 Ø 19 mm x 1 mm	12
H-7		Allen Key(L=110MM)	2
H-8		Flat Washer M6 Ø 14 mm x 1 mm	2

Assembly Preparation

Before Beginning:

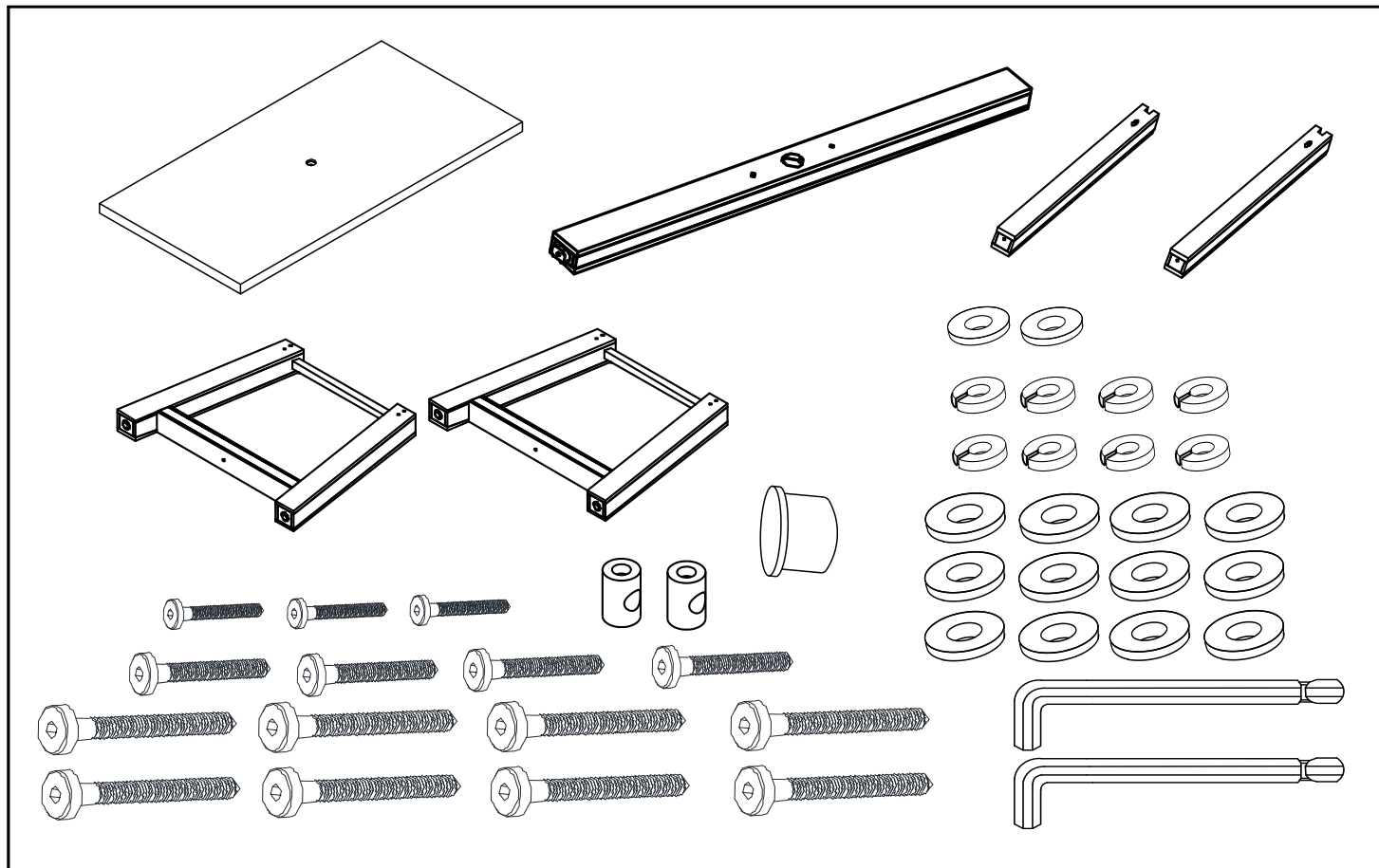

- Unpack all hardware bags and components to ensure you have all parts-



- Read instructions, cover to cover-



- Have 2 adults on hand for assembly-



- Do not assemble on flooring or carpet-



- Assemble on a clean non-marring surface (packing foam)-



- Save all packaging until finished-



- In case of missing parts, please contact nearest World Market store or our customer service call center 877-967-5362.

Assembly Steps

Step 1 **IMPORTANT:** It is highly recommended to have a second person to assist during this product assembly. Do not fully tighten allen bolts until all components are in place. Do not over tighten allen bolts.

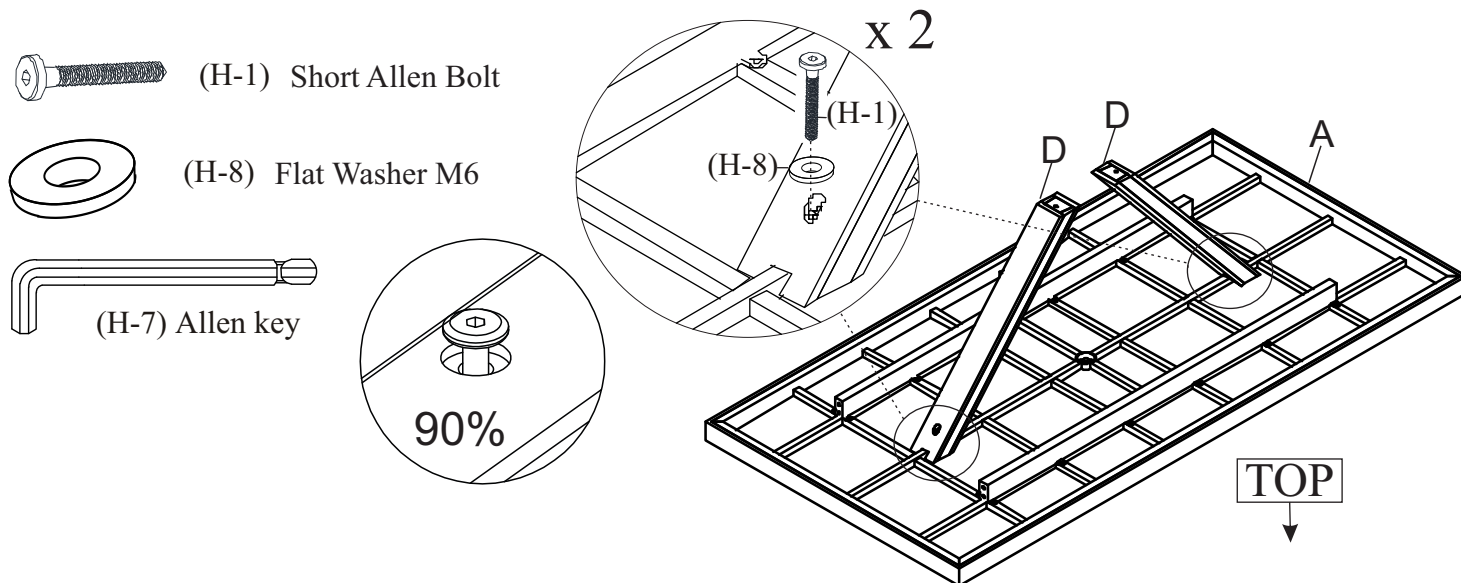

Using a second person to assist you, place Table Top (A) upside down onto a padded, non-marring surface. Next, position both Upper Wood Support Bars (D) as shown, making sure the notches at the ends of both bars attach over the metal frame on the underside of Table Top (A). Secure both Upper Wood Support Bars (D) using Short Allen Bolts (H-1) and Flat Washers (H-8). Engage the bolts using Allen Key (H-7) **but do not fully tighten them yet.**

Step 2

HINT: Thread a spare Short Allen Bolt (H-1) into the end of Barrel Nut (H-3) to keep the barrel thread aligned. Remove the spare Short Allen Bolt (H-1) when you're done.

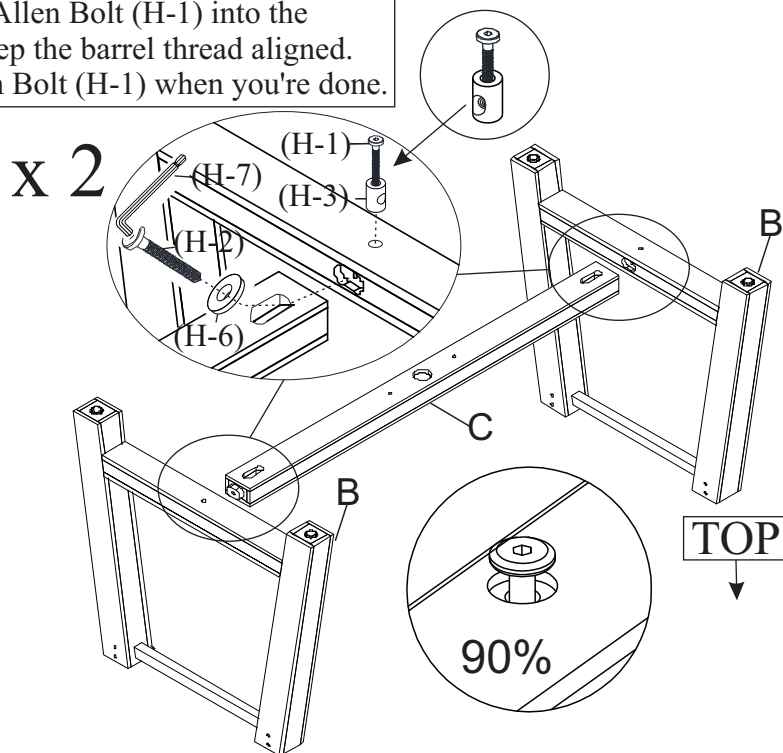
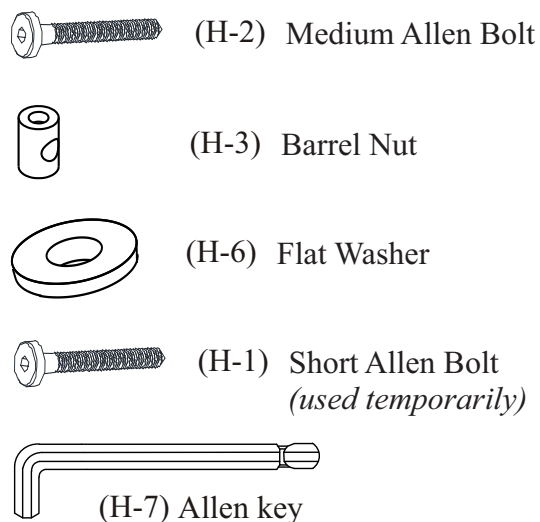



Arrange both Legs (B) with the tops facing downwards as shown. Attach Lower Wood Crossbar (C) to Legs (B) and secure both sides by attaching a Medium Allen Bolt (H-2) and Flat Washers (H-6) into a Barrel Nut (H-3). Use a spare Short Allen Bolt (H-1) threaded into Barrel Nut (H-3) to hold the threads aligned while engaging Medium Allen Bolt (H-2). Engage Medium Allen Bolts (H-2) using Allen Key (H-7) **but do not fully tighten them yet.** Once Barrel Nuts (H-3) have been engaged, remove the spare Short Allen Bolt (H-1).

Assembly Steps

Step 3 **IMPORTANT:** It is highly recommended to have a second person to assist during this assembly step.

 (H-4) Long Allen Bolt

 (H-5) Spring Washer M8

 (H-6) Flat Washer

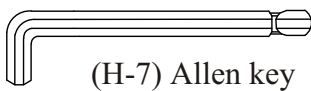
 (H-7) Allen key

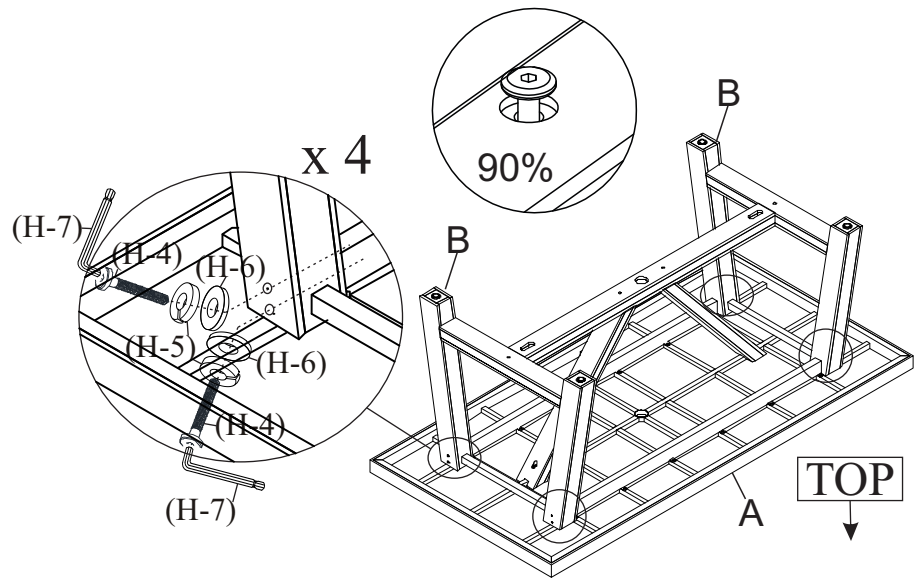

Using a second person to assist you, carefully lower the leg assembly (from Step 2) down onto the Table Top (A) assembly (from Step 1). Align the holes on Legs (B) with the metal apron frame on Table Top (A) and secure each leg to the frame using 2 Long Allen Bolts (H-4), Spring Washers (H-5) and Flat Washers (H-6). Engage the bolts using Allen Key (H-7) **but do not fully tighten them yet.**

Step 4

 (H-2) Bolt M8 x 80mm

 (H-6) Flat Washer

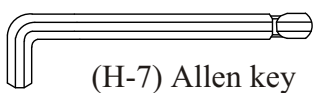
 (H-7) Allen key

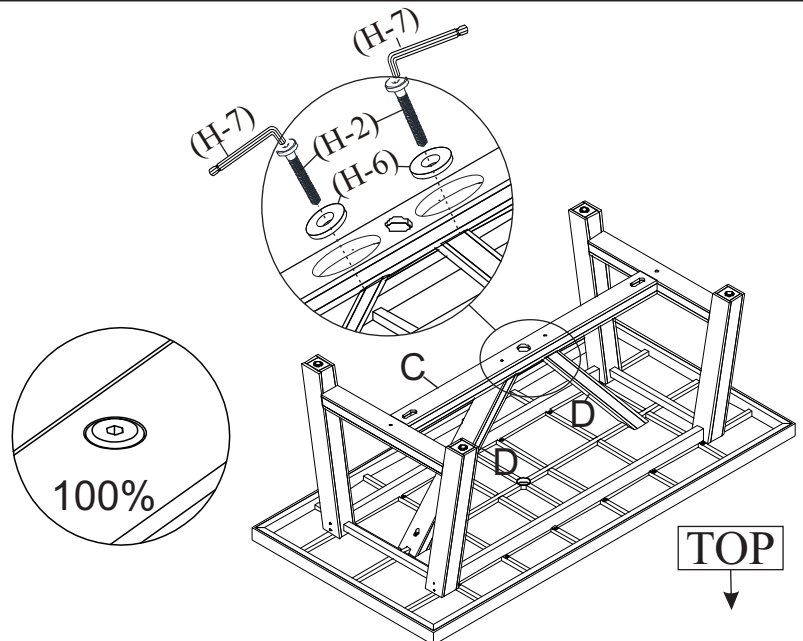

Secure both Upper Wood Support Bars (D) to Lower Wood Crossbar (C) using Medium Allen Bolts (H-2) and Flat Washers (H-6). Engage the bolts and then **FULLY TIGHTEN** them using Allen Key (H-7).

Assembly Steps

Step 5

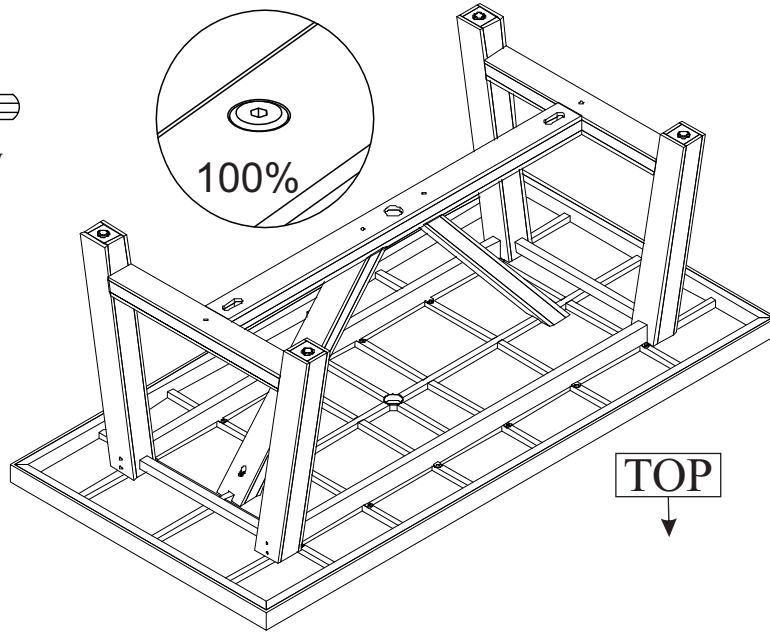
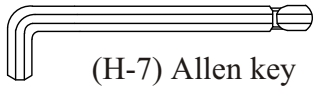

FULLY TIGHTEN all Allen Bolts from Steps 1-4 at this time using Allen Key (H-7).

Step 6

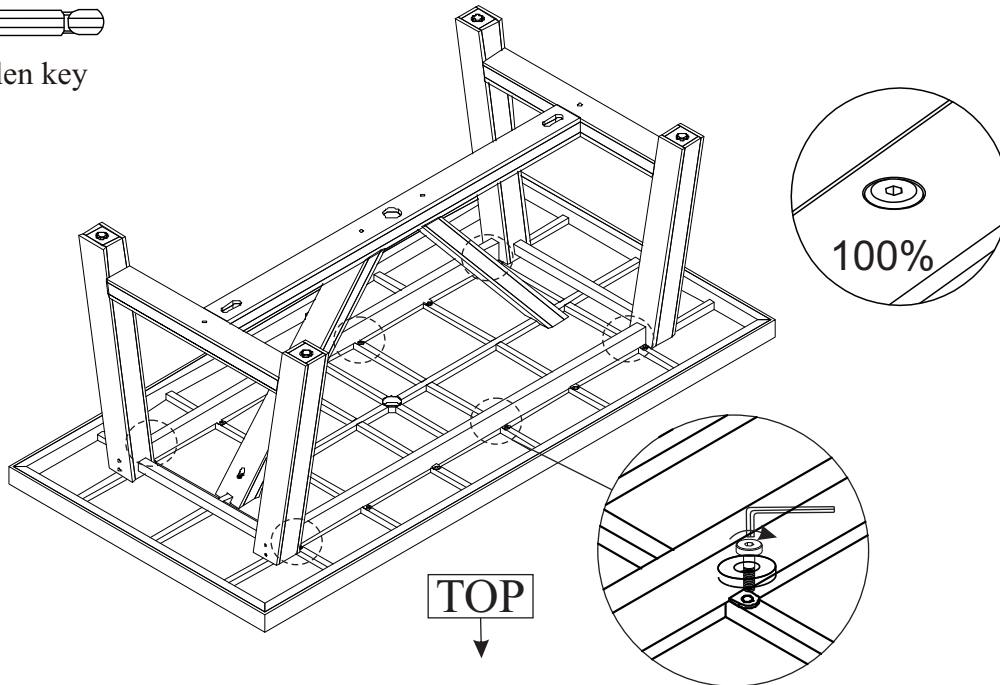
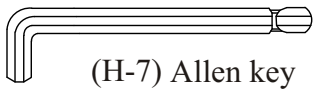

NOTE: Table Top (A) comes with a pre-installed metal frame. Ensure that all pre-installed bolts (12pcs total) securing the metal frame are **FULLY TIGHTENED** using Allen Key (H-7).

Assembly Steps

Step 7 **IMPORTANT:** It is highly recommended to have a second person to assist during this assembly step.

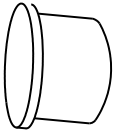

Umbrella Hole Cap



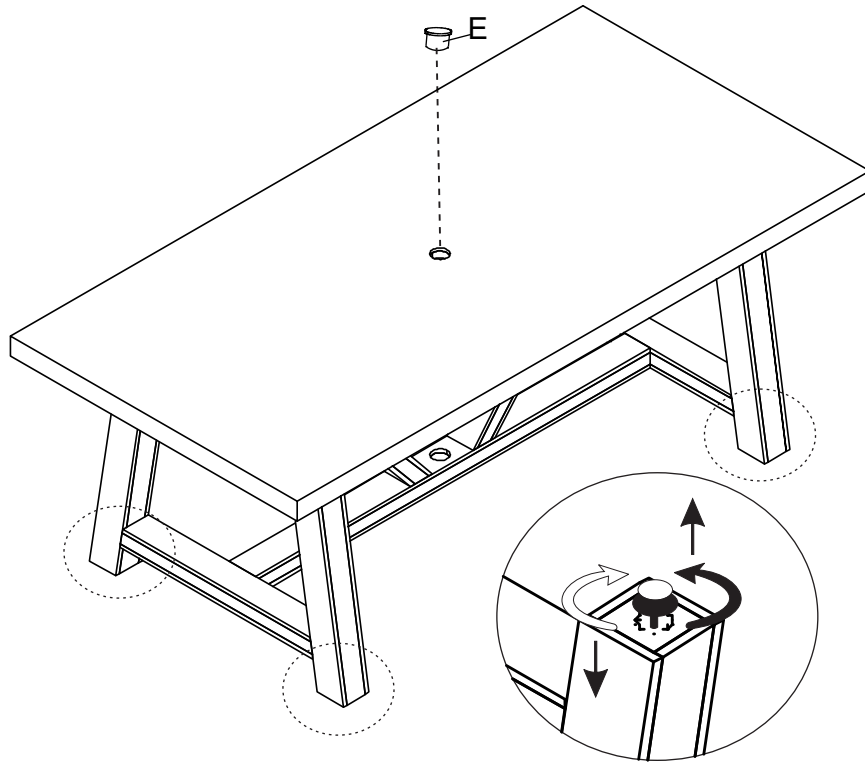



↑
TOP





Using a second person to assist you, carefully turn the table assembly upright. Place Umbrella Hole Cap (E) into the umbrella hole at the middle of the table. Position the table in its desired location before making any final adjustments using the adjustable floor levelers (if needed). Assembly is now complete and the table is ready for use.

NOTE: Check that all bolts are fully tightened every 3 months to ensure stability.

Care & Maintenance

-  • Do not put hot items directly on furniture surface.
-  • Do not clean furniture with harsh cleansers or polish.
-  • Do not place furniture near heating or cooling vents.
-  • Do not write on furniture without a padded barrier to protect the surface.
-  • Store furniture or use an appropriate furniture cover during cold or inclement weather.
-  • Not for commercial use. For residential use only.

-
-  • Dust and pick-up spills using a clean, non-colored, lint-free cloth.

-  • Stains may be removed with mild soap solution and damp cloth.

CAUTION: As with any wood, the color may fade if left in direct sunlight of inclement weather. Minor cracking may occur with age. These are naturally occurring features of wood and do not affect product performance.

We recommend using our Natural Outdoor Wood Furniture Finish (sold separately) to help preserve and protect the wood and finish. Do not apply any finish to the table top surface.